

SCIENTEMP CORP.

Medical Freezers ~ Pharmacy Freezers ~ Culture Storage Freezers ~ Blood Storage/Blood Plasma Freezers
Adhesive Storage Freezers ~ Industrial/Manufacturing Freezers ~ Flammable and Explosion Proof Freezers

Your Scientemp freezer has been pre-programmed at the factory and ready for use. You only have to:

- 1) Plug your freezer into its own dedicated circuit and
- 2) Set your desired temperature on the controller

*~~To set the desired set point temperature, press and hold the * button, then while holding down the * press the UP arrow to increase the set point temperature or press the DOWN arrow to decrease the set point temperature.*

- When uncrating, do not discard the Dark Grey Styrofoam Sublids inside the freezer. **The Sublids are necessary to maintain correct temperature, moisture control and economy of operation.*
- Provide at least 3” of space around the freezer for ventilation. Avoid placing the freezer in locations exposed to direct sunlight, heat registers or any other heat source.
- Alarm On/Off switch should remain in the “Off” position until the freezer reaches desired set point temperature. When the temperature has been reached, turn the alarm switch to the “On” position.
- Cabinet should not be loaded with product until the cabinet has operated for 24 hours at the desired set point temperature.

Maintenance tips for your Scientemp Freezer:

- Regularly remove any frost build up by using a plastic/wooden scraper.
- Check and replace batteries on Alarm Signal System and Chart Recorder (if equipped) on a regular base.
- The black finned condenser in the refrigeration compartment of the freezer, should be cleaned of dust and debris about once a year (or more often if freezer is located where excessive dust and dirt may occur)

~~This can be done by vacuuming carefully or by using forced air to blow the debris off.

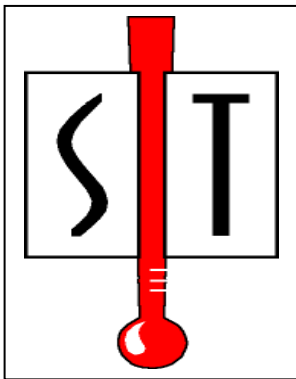

Scientemp Corp.

3565 S. Adrian Hwy
Adrian, Michigan 49221

Phone: 517-263-6020

Fax: 517-263-5492

Website: www.scientemp.com

OPERATING AND INSTALLATION MANUAL MODEL 85-3.1A

This cabinet has passed the
QUALITY CONTROL INSPECTION
and meets the high standards at Scientemp Corp.
This inspection includes the complete refrigeration
system, cabinet construction and finish.

CONTACTING FACTORY

For reference and when contacting the factory, please have your freezer information ready:

MODEL NUMBER: _____

SERIAL NUMBER: _____

DATE SHIPPED: _____

PURCHASED FROM: _____

The Model Number and Serial Number can be found on the data plate attached to the cabinet on the back upper left corner.

**SCIENTEMP CORP.
3565 S. ADRIAN HIGHWAY
ADRIAN, MICHIGAN
49221**

**TELEPHONE: 517-263-6020
FAX: 517-263-5492**

**Sales Contacts:
Tracy Proffitt
517-263-6020 Ext. 104
tracy@scientemp.com**

**Kelli Wadke
517-263-6020 Ext. 102
kelli@scientemp.com**

**General Email: scientemp@scientemp.com
Web site: www.scientemp.com**

IMPORTANT! Do not discard the Dark grey foam sublids from inside the chest freezer. The sublids are necessary to maintain correct temperature, moisture control and economy of operation.

Before you get started, please take a few minutes to read through this manual.

1. MOVING YOUR FREEZER

The refrigeration system of the cabinet is designed to operate with the cabinet located on a flat surface. **Do not tilt the cabinet more than 30° to any side.** If the cabinet must be tilted on an angle for handling or moving purposes allow it to sit in an upright position for at least two (2) hours prior to starting.

2. SAFETY PRECAUTIONS

In this manual, the words **WARNING** and **CAUTION** mean the following:

***WARNING:** a potentially hazardous situation, which if not avoided, could result in serious injury or death.

***CAUTION:** a potentially hazardous situation, which if not avoided, may result in minor or moderate injury or damage to equipment.

Before installing, using or maintaining this product, please be sure to read this manual carefully. Failure to follow these instructions may cause this product to malfunction, which could result in injury or damage.

Below are important safety precautions that apply to this product:

- Use this product only in the manner described in the product literature and in this manual. Before using it, verify that this product is suitable for its intended use.
- Do not modify system components.
- The cabinet must be properly grounded in conformity with national and local electrical codes. Never connect the unit to overloaded power sources.
- Disconnect the unit from all power sources before cleaning, troubleshooting or performing other maintenance on the cabinet.

3. CHOOSING A LOCATION

3.1 Air Circulation

The cabinet should be situated to allow proper air circulation in a well ventilated room. Provide at least 3” of space around the freezer for ventilation. Avoid placing the freezer in locations exposed to direct sunlight, heat registers or any other heat sources.

***NOTE:** The cabinet must be installed on a sturdy, solid, level floor resting firmly on all four mounting points.

3.2 Ambient Temperature

Do not place cabinet in sunlight, near heating diffusers, radiators or other sources of heat. Drafts from fans, air conditioning or open doors can also affect the product temperature. The ambient temperature range at the location must be 59 to 90°F (15 to 32°C).

***Warning:** This unit is not a “rapid-freeze” device. Freezing large quantities of liquid or high water content items will temporarily increase the compressors to operate for prolonged periods of time. Attempting to utilize this

freezer improperly may jeopardize safety or cause undue stress or damage to the refrigeration compressors.

Avoid opening the door for extended periods of time since chamber air will escape rapidly. Room air, which is higher in humidity, will replace chamber air and may cause frost to develop in the chamber more rapidly.

4. CHECK OUT YOUR NEW FREEZER

4.1 Lid Seal

If the lid gasket does not seal along the front edge, relieve the compression of the gasket along the back edge by loosening the hinge screws where they attach to the cabinet. Raise the lid slightly and then retighten the screws.

4.2 Interior Compartment Temperature

The temperature is controlled by a CAL 9500 digital temperature controller. When you first power up the freezer, the high stage compressor and fan will start and operate for 3 to 6 minutes before the low stage compressor starts. Pull down to minimum temperature will take from 3 to 6 hours, depending on ambient temperature and size of cabinet. The high stage compressor runs 100% of the time. The low stage compressor will cycle on and off to maintain the temperature of the controller setting. Set the control to the desired set point. To view the set point temperature, press the * and the UP arrow keys together. To decrease the set point temperature, press the * and the DOWN arrows keys together.

Freezers are shipped from the factory with the indicating digital control programmed for proper operation. All but the temperature settings may be adjusted. The temperature sensor is a type “T” thermocouple located on the front wall of the inner-liner.

4.3 Alarm Signal System

The Alarm should be kept in the “OFF” position until the cabinet temperature has reached the appropriate setting. When the temperature has been reached, the temperature alarm should be switched to the “ON” position and is now ready to operate. It will monitor “temperature rise” and “power-failure”. The control is factory set to operate the alarm at approximately 10°F (6°C) above the set temperature. No further adjustment is necessary unless a spread other than this is desired. In the event a temperature spread of more or less than factory set is desired, refer to your digital temperature control manual.

NOTE: It is recommended to keep the freezer operating continually rather than turning the freezer off and on.

5 ELECTRICAL CONNECTIONS

5.1 Wiring

This cabinet is equipped with a three-prong (grounding) plug for your protection against shock hazards. The cabinet should be plugged directly into a properly grounded three-prong receptacle.

Where a two-prong wall receptacle is encountered, it must be replaced in accordance with the National Electronic Code and local codes and ordinances. A licensed electrician must do the work.

The electrical outlet should not be controlled by a wall switch, which might be turned off accidentally.

***WARNING: Do NOT under any circumstances cut or remove the round grounding prong from the cabinet plug.**

***CAUTION:** For personal safety and trouble-free operation, this cabinet must be properly grounded before it is used. Failure to ground the equipment may cause personal injury or damage to the equipment. Always conform to the National Electrical Code and local codes. Do not plug in the cabinet to overloaded power lines.

Consult a licensed electrician if you have ANY doubt about the grounding of your wall receptacle. Only a licensed electrician can determine the polarization of your wall receptacle.

6 DANGERS OF A LOW TEMPERATURE FREEZER

Any temperature below 0° Centigrade or 32° Fahrenheit provides a potential condition to cause freezing of water or material containing water. Material containing water solutions of salt or sugar will freeze at a slightly lower temperature, depending on the content of the solution.

Because all warm-blooded creatures are composed of a great percent of water with salinity, they are subject to freezing whenever the body cells, parts or extremities reach temperatures below freezing.

6.1 When Skin Freezes

When your skin is exposed to subfreezing temperatures for an extended amount of time, it can freeze. Your blood vessels constrict in response to dropping temperatures. This reduces the flow of blood and, therefore, the amount of oxygen to the tissues. When water in these tissues freezes and forms ice crystals, cell structure is destroyed.

Tissue damage from cell death interrupts circulation in the smallest blood vessels. Blood clots form and blood flow is further diverted away from the frozen tissue. At this point, your skin temperature drops and the injured area grows even colder.

The first sign of frostbite may be a slightly painful tingling sensation, which often is followed by numbness. Your skin may look pale, and feel hard, cold and numb.

In the event of frostbite, warming is vital. Carefully warm frost-bitten areas gradually. Place your hands directly on the skin of warmer areas of your body. If possible, immerse your hands in water that is slightly above normal body temperature (about 100°F or 37.8°C), or which feels warm to someone else, until your normal color returns. Do not use direct heat. Seek medical attention as quickly as you can.

***CAUTION: Wear protective clothing while either handling or coming in contact with inside of freezer. Hands should be dry and protected by using gloves. Insulated gloves are best for extended use when handling frozen product. Sleeves or arm-length insulated gloves should protect arms. Coats, insulated aprons, etc. should protect other parts of the body that may be exposed to the cold.**

7 REFRIGERATION COMPARTMENT

The refrigeration system of a Scientemp freezer is hermetically sealed. It requires no maintenance. However, in areas where excessive dust and dirt collect, the condenser must be kept clean. To clean the condenser, remove power to freezer. Remove the guard on the back of the freezer. Use forced air and a vacuum to clean dirt and debris from the condenser and refrigeration compartment periodically.

7.1 Fan

The fan motor has lifetime lubrication. It requires no maintenance.

7.2 Frost removal

1. While the freezer is running the frost may be removed with a plastic or wooden scraper or spatula. Do not use metal or sharp objects such as an ice pick, as this will cause serious damage to the finish of the inner-liner of the freezer. The frost and ice may be collected in a pan, towel or any device to prevent it from falling to the bottom of the freezer or onto the material stored in the freezer. Most of

the frost and ice collects near the top edge and is easily removed.

2. In the case where the freezer is not loaded, frost and ice may be removed by disconnecting the power until the frost and ice thaw. After defrosting, dry the freezer compartment interior and plug freezer back in.

8 ALARM SIGNAL SYSTEM

SCIENTEMP Alarm signal system is a dependable, compact unit designed to audibly alert you for temperature rise and power failure. The Alarm is an audible and visual signal-warning system. It produces a penetrating, repeating sound to alert you.

The Alarm system, used in conjunction with a SCIENTEMP low temperature cabinet, will monitor “temperature-rise” and “power-failure”.

1. Temperature rise and power failure is indicated by flashing red light accompanied by a repeating audible signal in the form of beep-beep-beep.

The Alarm system is powered by two (2) “9 volt” batteries. It is important that the batteries be placed correctly in the holders for the proper polarity. We recommend batteries be replaced once a year to assure performance of the alarm. Press the “**test button**” for frequent checks on battery life and performance. If the Alarm fails to operate properly, it may be due to a weak battery, which should be checked first.

8.1 Testing the Alarm Signal System

Switch the Alarm to the “**ON**” position. To simulate “temperature-failure”, lower the set point temperature on the controller to trigger the alarm. Once in operation, pressing the “**TEST**” button checks for battery life.

9 REMOVING & INSTALLING CABINET LID

***CAUTION:** HINGES ARE SPRING LOADED

1. Remove the two top and one-bottom screws holding the lower portion of the hinge to the cabinet.
2. While applying pressure to hold the hinge to the cabinet, remove the remaining bottom screw. Carefully let the spring tension lift the hinge from the cabinet.
3. Remove the lid from the cabinet and remove the four screws holding the upper portion of the hinge to the lid.
4. To reinstall the lid, reverse the above procedure.
5. Check the lid for alignment and the gasket for a proper seal. Use the slotted hinge holes to make any required adjustments.

10 DIGITAL TEMPERATURE CONTROLLER REPLACEMENTS

Remove the following items in order shown:

1. Remove the instrument panel, which is held in place by four (4) screws.
2. Remove the wires from the controller.
3. Remove the mounting brackets on the controller.
4. Remove the controller from the instrument panel.
5. Insert new controller into instrument panel, reverse procedures. When rewiring use enclosed wiring diagram.

11 CHANGING THERMOCOUPLE (T/C)

1. Disconnect power and let freezer warm up.
2. Remove stainless steel corner slips from front two corners.
3. Remove white plastic breaker by pulling up and out on edge next to inner liner.
4. Lift insulation and remove hard board sub breaker.
5. Remove instrument panel (4 screws) and lay in front of freezer face down.
6. Remove T/C wires from terminals.
7. Remove 3/4" rubber grommets from cabinet bottom & inner liner.
8. Remove clips over T/C
9. Tape bulb of new T/C securely to control end of old T/C.
10. From the top, reach into insulation and pull old T/C up through insulation bringing new T/Cup with it.
11. Remove tape and old T/C.
12. Feed new T/C through 3/4" hole and secure inside inner liner the same as old T/C. Coil excess in insulation.
13. Replace breaker, sub breaker and grommets using reverse procedure.
14. Secure T/C wires to CAL 9500 control.
15. Reposition control panel.

INSTRUMENT PANEL FEATURES

! This page can be photocopied and used as a visual aid and bookmark when working in other parts of the manual.

Green LED:
Setpoint 1 output indicator

Green Display:
Process variable or
Function/Option

Upper Red LED:
Setpoint 2 output
indicator

Lower Red LED:
Setpoint 3 output
indicator



Right Red LED:
Program Holdback
indicator

Orange Display:
Setpoint value or
program selection

ADJUSTMENTS

To enter or exit **program mode:**

Press ▲ ▼ together for 3 seconds

To scroll through **functions:**

Press ▲ or ▼

To change **levels or options:**

Press * ▲ together or * ▼ together

To view setpoint units:

Press *

To increase setpoint:

Press * ▲ together

To decrease setpoint:

Press * ▼ together

To reset latched alarm or tune fail:

Press ▲ ▼ together briefly

To run or Hold a program:

Press * ▼ together for 3 seconds

Notes: If in difficulty by becoming "lost" in program mode, press ▲ and ▼ together for 3 seconds to return to display mode, check the INSTRUMENT ADJUSTMENTS above and try again.

When in program mode, after 60 seconds of key inactivity the display will revert to either *inPt : nonE* or, if the initial configuration has been completed, the measured value. Any settings already completed will be retained. During Program Configuration it is recommended that this feature is inhibited. Select *ProG StAY* in Level 4.

Cal 9500 Configuration Data

Level 3

SP1.d – rly

SP2.d – rly

Burn – uP.SC

rEV.d – 1d.2r

rEV.L – 1i2n

SPAn – 0.0

Zero – 3 (Note: Only Change this parameter if calibrating unit, value may vary.)

ChEk – off

rEAd - Var

tECh – CtA

Ver – 953

rSET – none

Level 2

SP1.P – 0

hAnd – off

PL.1 – 100

PL.2 – 100

SP2.A – Dv.hi

SP2.b – none

di SP – 0.1

hi .SC – 100

Lo. SC – -100

in Pt – tc t

unit – C

Level 1

tune – off

band – 0.3

int.t – off

dEr.t – off

dac – 0.5

cyc.t – on.of

ofSt – 0.0

SP.Lk – off

SPrr – 0

SPrn – off

SoAk – --

Set.2 – 6 (alarm deviation)

bnd.2 – 0.1

Cyc.2 – on.of

Level P

Prog – 1

Run - OFF

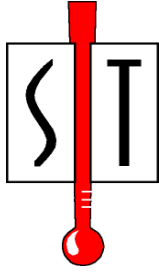

Scientemp™

3565 S. Adrian Hwy ♦ Adrian, MI 49221
800-968-2653 ♦ 517-263-6020 ♦ Fax 517-263-5492

Standard Warranty

Applies Only Within the Continental United States

SCIENTEMP WARRANTS TO THE ORIGINAL PURCHASER

FIRST 18 MONTHS – The cabinet and all of its parts shall be free of defects in material and workmanship under normal use and service for a period of 18 months from the date the unit has been shipped from our facility. Scientemp's sole obligation under this warranty shall be limited, at its option, to either repairing or replacing any part of the cabinet determined by an authorized service agent to be defective. Scientemp reserves the right to repair the freezer at our facilities.

THE SCIENTEMP STANDARD WARRANTY DOES NOT COVER

TRANSPORTATION COSTS – Scientemp shall not be responsible for transportation or incidental costs incurred in connection with the repair or replacement of a cabinet or any of its parts.

ABUSE, MISUSE, ACCIDENTS – Scientemp shall not be responsible for parts or assemblies which upon inspection are determined by an authorized Scientemp Service Agent to have been subjected to misuse, neglect, alteration, accident, abuse, damage during transit or delivery, or by fire or flood.

CONSEQUENTIAL DAMAGES – IN NO EVENT SHALL SCIENTEMP CORP BE LIABLE FOR SPECIAL, INDIRECT OR CONSEQUENTIAL DAMAGES, INCLUDING WITHOUT LIMITATION, PRODUCT LOSS OR PRODUCT SPOILAGE CLAIMS, NOR FOR ANY DELAY IN THE PERFORMANCE OF THIS WARRANTY DUE TO CAUSES BEYOND ITS CONTROL.

GENERAL

The standard warranty and any service contract related to the STANDARD WARRANTY shall apply only to the products sold and used within the boundaries of the Continental United States.

Users may file warranty claims either directly with Scientemp Corp, 3565 S. Adrian Hwy, Adrian, MI 49221, or with the seller from whom the cabinet was purchased. All claims must be supported by information concerning the alleged defect and specifically identified by the Serial Number of the cabinet.

THERE ARE NO OTHER WARRANTIES EXPRESS, IMPLIED, OR STATUTORY, EXCEPT THIS WARRANTY, WHICH IS IN LIEU OF ALL OTHER WARRANTIES INCLUDING TO THE EXTENT PERMITTED BY LAW, ANY IMPLIED WARRANTY OR MERCHANTABILITY OR FITNESS FOR A PARTICULAR PURPOSE.

DO NOT DRILL HOLES IN CABINET

Refrigeration tubing and wiring is routed through the cabinet walls. Leaks, wet insulation or electrical problems caused by drilling holes are not covered by warranty.

CASCADE WIRING DIAGRAM-CAL 9500 CONTROLLER, CHART RECORDER,
DUAL 9 VOLT BATTERY ALARM, 115VOLT/60Hz

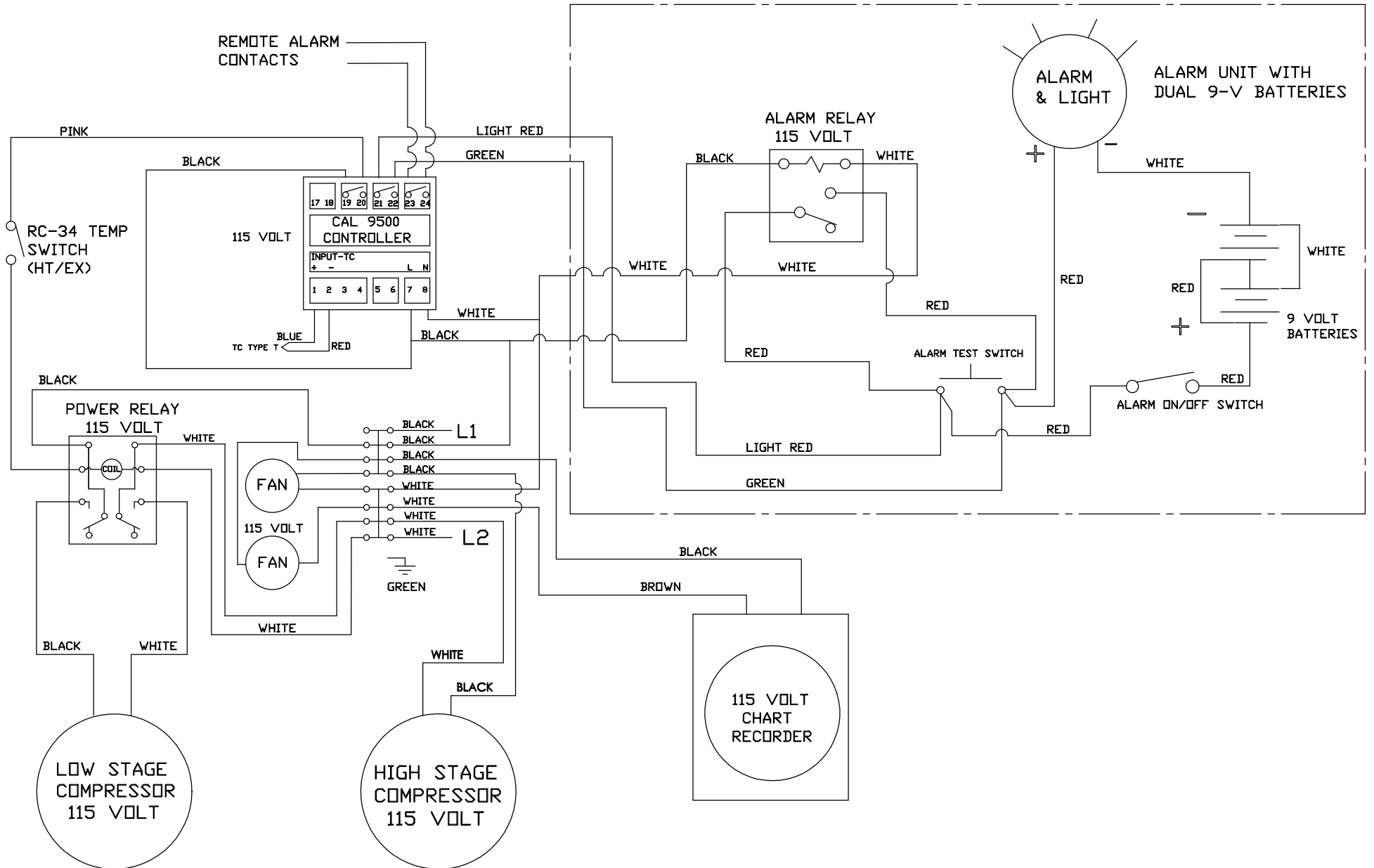

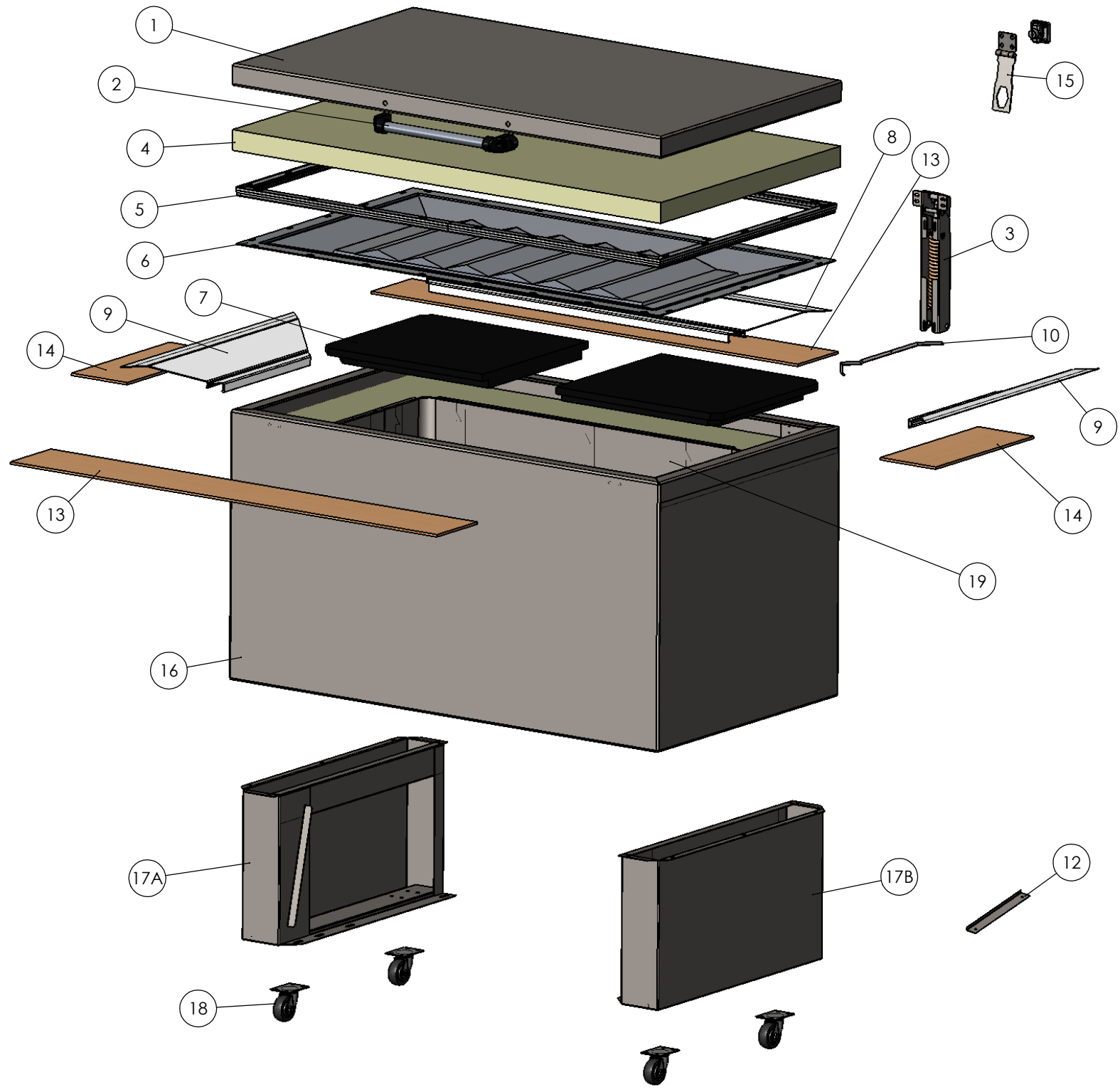

Diagram Number	Part Description	Model # 85-3.1
1	Outer Metal Lid Pan	5010-3.1
2	Tube Style Handle	1027-3
3	Hinge Assembly	1038
4	Lid Insulation	Call
5	Lid Gasket (Includes clips not shown)	1003-3.1
6	Plastic Lid Liner	1008-3.1
7	Dark Grey/Black Sub Lid (Styrofoam)	1002-3.1
8	Breaker Strip Length	1095-3.1-L
9	Breaker Strip Width	1095-3.1-W
10	Stainless Steel Corner Cap	1098-3.1
11	Replacement Key (Not Pictured)	1031
12	Metal Sub Breaker Clip	Call
13	Sub Breaker Strip Length	1095-9
14	Sub Breaker Strip Width	1095-10
15	Keyed Hasp Lock Assembly	1028
16	Cabinet Shell	Call
17A	Leg Assembly (Left)	Call
17B	Leg Assembly - (Right)	Call
18	Standard Non- Locking Casters	1030-2
18	Locking Casters (Optional-Not Shown)	1030-2L
19	Interior Tank Assembly	5006-3.1

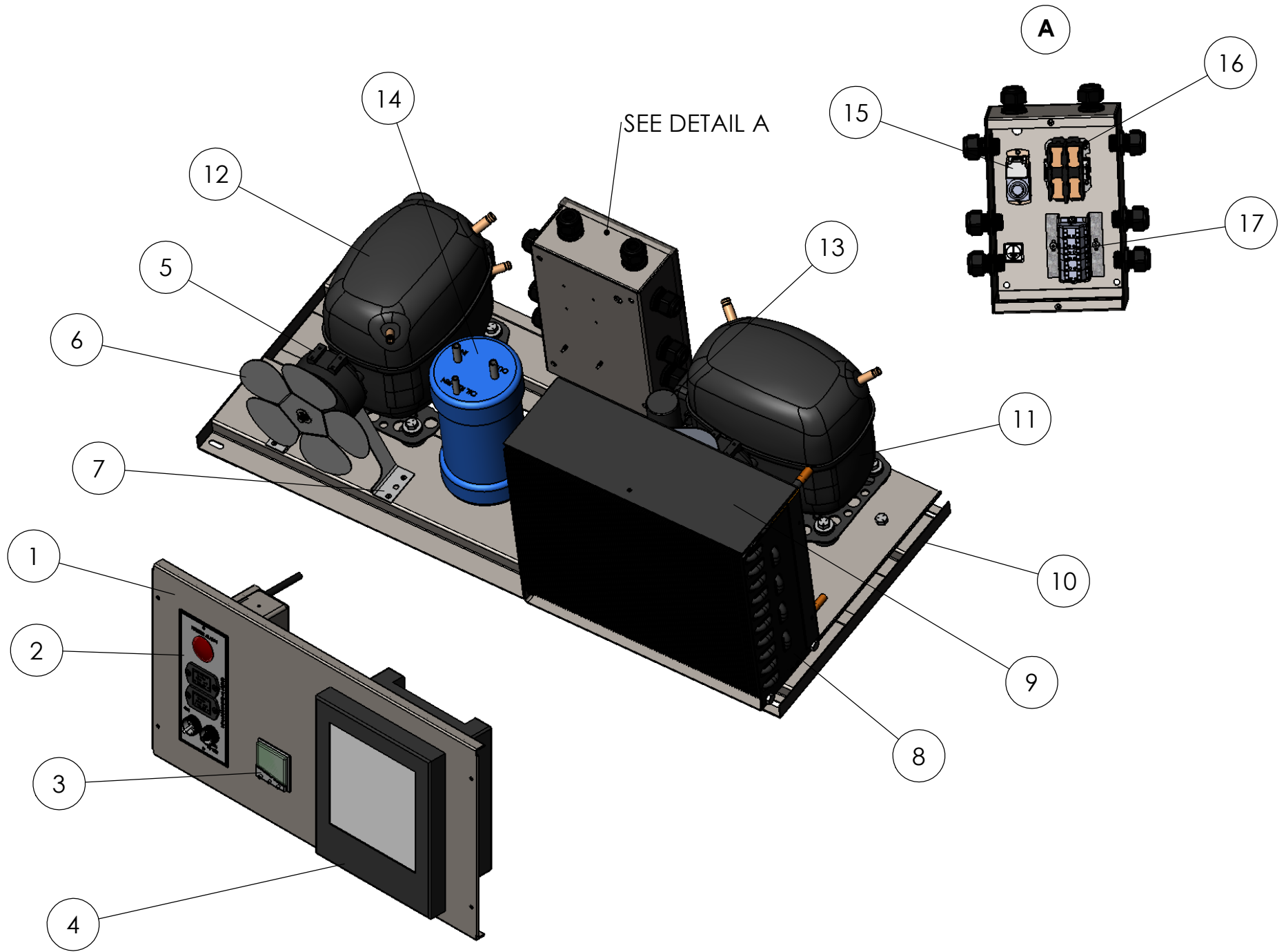

Diagram Number	Part Description	Model # 45-3.1 or 85-3.1
1	Plain Instrument Panel	1076-3.1-1
1	Chart Recorder Instrument Panel	1076-3.1-2
2	Sonalarm Signal System	5006
3	CAL9500 Temperature Controller	5001
4	6" Chart Recorder (115V)	5016-A-7
4	6" Chart Recorder (230V)	5016-B-7
5	Fan Motor (115V)	1136-A
5	Fan Motor (230V)	1136-B
6	7" Fan Blade	1140-6
7	Fan Bracket (Holds Fan Motor)	1138
8	Black Fin Steel Condenser	Call
9	Cardboard Shroud	Call
10	Unit Rail	1098-3.1
11	High Stage Compressor with Electrics (Please supply Compressor Model #)	Call
12	Low Stage Compressor with Electrics (Please supply Compressor Model #)	Call
13	Compressor Electrics (Capacitor)	Call
13	Compressor Electrics (Relay)	Call
14	Oil Separator (85-3.1 only)	8071
15	RC34 Switch (Heat Exchanger Control)	8061
16	Power Relay (115V)	7511-A
16	Power Relay (230V)	7511-B
17	Replacement Wago Blocks	Call